

## H112 Large format motorised stage



The H112 motorised stepper stage from Prior is one of a full range of motorised stepper stages. A range of sample holders are available and stage inserts can be customised for virtually any application, meaning that the H112 stage combines high precision with versatility.

The H112 is especially well-suited for applications that typically involve large specimens, such as scanning semi-conductor wafers, photo masks, flat panel displays and printed circuit boards. 300 mm (12") wafers can easily be accommodated by this stage. Transmitted light applications are also possible with a 250 x 250 mm transmitted light travel area.

Prior stages are precisely engineered and ideal for a wide variety of demanding applications. They are compatible both with Prior motor controllers such as the ProScan<sup>®</sup> III, and can easily be incorporated into OEM applications. The controller can be accessed via USB, RS-232 serial port, or with an optional joystick or keyboard.

### H112 features

- Travel 302 x 302 mm (12" x 12")
- Repeatability of  $\pm 0.7 \mu\text{m}$
- Fine resolution and repeatability combined with a large scanning area.
- X and Y limit switches
- 2 mm or 5 mm pitch recirculating ball screws available
- Encoded variants available

## H112

Large format motorised stage

### Specifications

Stage	H112/2	HE12/2
Uni Directional Repeatability (µm)	± 0.7	± 0.7
Minimum Step Size (µm)	0.04	0.1
Suggested Speed (mm/s)	40	40
Max travel range (mm)	302 x 302	302 x 302
Ball Screw Pitch (mm)	2	2
Encoders (µm)	No	0.1
Load capacity (kg)	25	25
Weight (kg)	14.5	14.5

\*Steps per Revolution of Motor

Specifications are valid only when used with a ProScan II or higher controller. Specifications are obtained via the Prior method of testing and analysis with backlash correction enabled, based on performance with IST enabled and measured over full range of travel.

### Dimensions

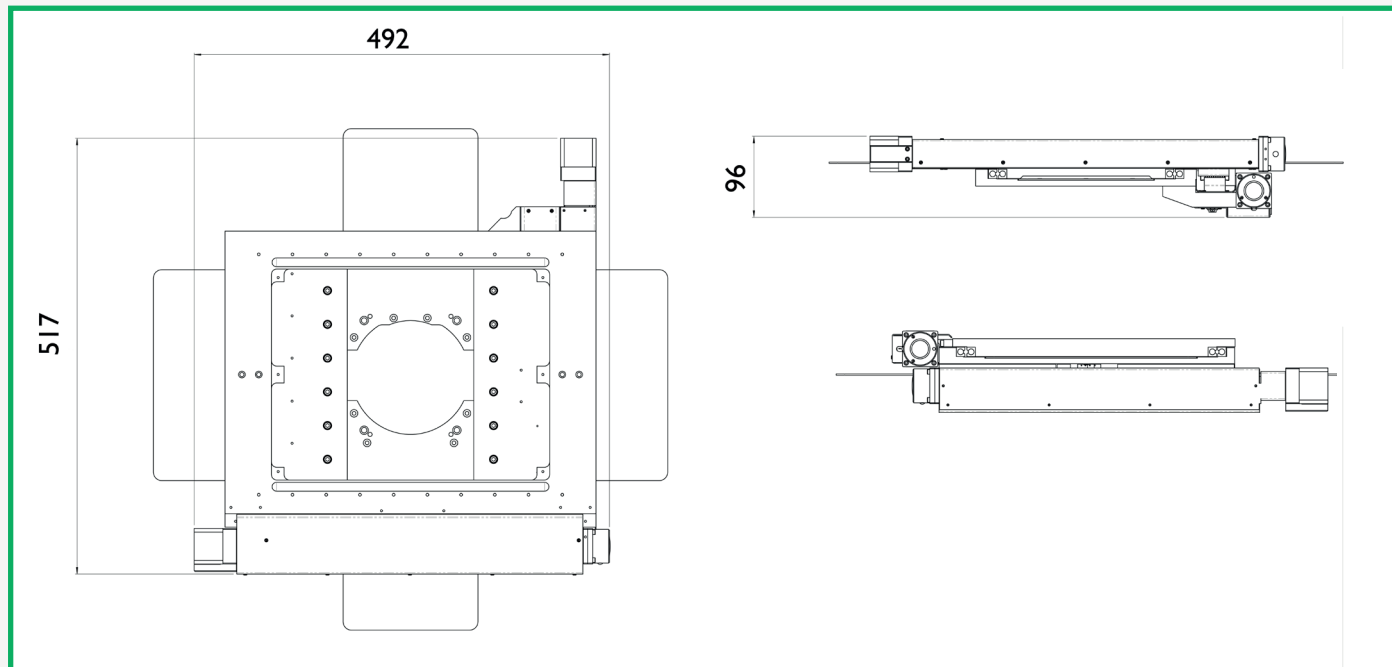

**Prior Scientific Ltd**

3-4 Fielding Industrial Estate • Wilbraham Road • Fulbourn • Cambridge • CB21 5ET • UK

t: +44 (0)1223 881711 • e: [uksales@prior.com](mailto:uksales@prior.com) • [www.prior-scientific.co.uk](http://www.prior-scientific.co.uk)



FM 61600



**Prior Scientific Inc**

80 Reservoir Park Drive • Rockland • MA. 02370 • U.S.A.

t: +1 781-878-8442 • e: [info@prior.com](mailto:info@prior.com) • [www.prior-us.com](http://www.prior-us.com)

Registered Address: Units 3/4 Fielding Industrial Estate • Wilbraham Road • Fulbourn • Cambridge • CB21 5ET • United Kingdom Registered in England 404087